

LM3914 Dot/Bar Display Driver

Check for Samples: [LM3914](#)

FEATURES

- **Drives LEDs, LCDs or Vacuum Fluorescents**
- **Bar or Dot Display Mode Externally Selectable by User**
- **Expandable to Displays of 100 Steps**
- **Internal Voltage Reference from 1.2V to 12V**
- **Operates with Single Supply of Less than 3V**
- **Inputs Operate Down to Ground**
- **Output Current Programmable from 2 mA to 30 mA**
- **No Multiplex Switching or Interaction Between Outputs**
- **Input Withstands $\pm 35\text{V}$ without Damage or False Outputs**
- **LED Driver Outputs are Current Regulated, Open-collectors**
- **Outputs can Interface with TTL or CMOS Logic**
- **The Internal 10-step Divider is Floating and can be Referenced to a Wide Range of Voltages**

DESCRIPTION

The LM3914 is a monolithic integrated circuit that senses analog voltage levels and drives 10 LEDs, providing a linear analog display. A single pin changes the display from a moving dot to a bar graph. Current drive to the LEDs is regulated and programmable, eliminating the need for resistors. This feature is one that allows operation of the whole system from less than 3V.

The circuit contains its own adjustable reference and accurate 10-step voltage divider. The low-bias-current input buffer accepts signals down to ground, or V^- , yet needs no protection against inputs of 35V above or below ground. The buffer drives 10 individual comparators referenced to the precision divider. Indication non-linearity can thus be held typically to 1/2%, even over a wide temperature range.

Versatility was designed into the LM3914 so that controller, visual alarm, and expanded scale functions are easily added on to the display system. The circuit can drive LEDs of many colors, or low-current incandescent lamps. Many LM3914s can be “chained” to form displays of 20 to over 100 segments. Both ends of the voltage divider are externally available so that 2 drivers can be made into a zero-center meter.

The LM3914 is very easy to apply as an analog meter circuit. A 1.2V full-scale meter requires only 1 resistor and a single 3V to 15V supply in addition to the 10 display LEDs. If the 1 resistor is a pot, it becomes the LED brightness control. The simplified block diagram illustrates this extremely simple external circuitry.

When in the dot mode, there is a small amount of overlap or “fade” (about 1 mV) between segments. This assures that at no time will all LEDs be “OFF”, and thus any ambiguous display is avoided. Various novel displays are possible.

Much of the display flexibility derives from the fact that all outputs are individual, DC regulated currents. Various effects can be achieved by modulating these currents. The individual outputs can drive a transistor as well as a LED at the same time, so controller functions including “staging” control can be performed. The LM3914 can also act as a programmer, or sequencer.

The LM3914 is rated for operation from 0°C to +70°C. The LM3914N-1 is available in an 18-lead PDIP (NFK) package.

The following typical application illustrates adjusting of the reference to a desired value, and proper grounding for accurate operation, and avoiding oscillations.



Please be aware that an important notice concerning availability, standard warranty, and use in critical applications of Texas Instruments semiconductor products and disclaimers thereto appears at the end of this data sheet.

All trademarks are the property of their respective owners.

TYPICAL APPLICATIONS

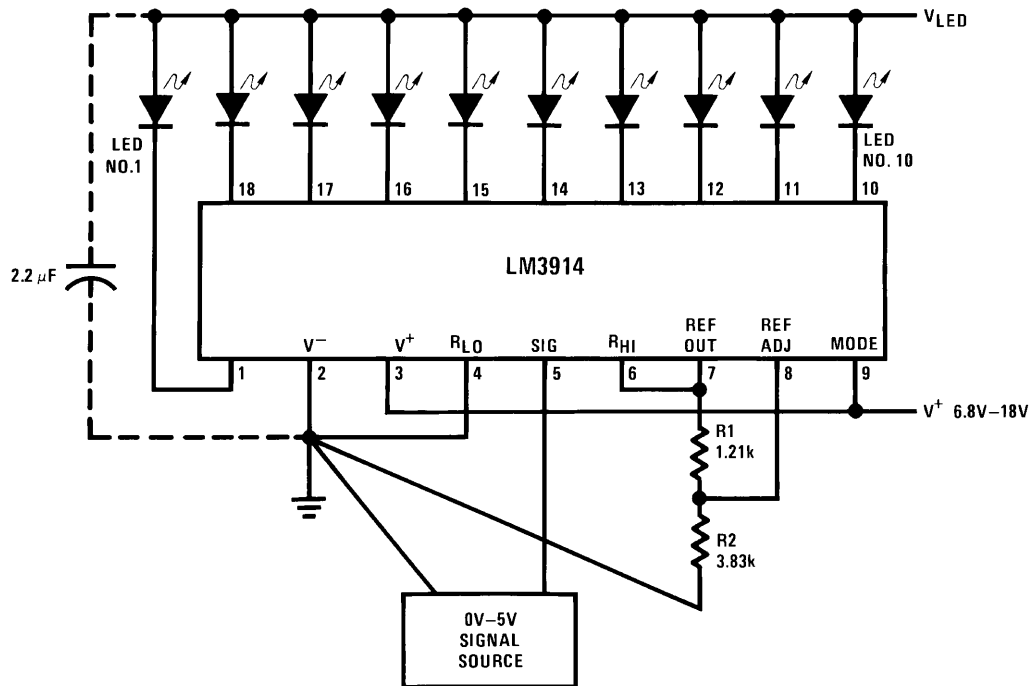

$$\text{Ref Out } V = 1.25 \left(1 + \frac{R_2}{R_1} \right)$$

$$I_{\text{LED}} \cong \frac{12.5}{R_1}$$

Note: Grounding method is typical of *all* uses. The 2.2µF tantalum or 10 µF aluminum electrolytic capacitor is needed if leads to the LED supply are 6" or longer.

Figure 1. 0V to 5V Bar Graph Meter



These devices have limited built-in ESD protection. The leads should be shorted together or the device placed in conductive foam during storage or handling to prevent electrostatic damage to the MOS gates.

ABSOLUTE MAXIMUM RATINGS⁽¹⁾⁽²⁾

Power Dissipation ⁽³⁾ PDIP (NFK)	1365 mW
Supply Voltage	25V
Voltage on Output Drivers	25V
Input Signal Overvoltage ⁽⁴⁾	±35V
Divider Voltage	–100 mV to V ⁺
Reference Load Current	10 mA
Storage Temperature Range	–55°C to +150°C
Soldering Information PDIP Package Soldering (10 seconds)	260°C
PLCC Package Vapor Phase (60 seconds)	215°C
Infrared (15 seconds)	220°C

See <http://www.ti.com> for other methods of soldering surface mount devices.

- (1) Absolute Maximum Ratings indicate limits beyond which damage to the device may occur. Operating Ratings indicate conditions for which the device is functional, but do not ensure specific performance limits. Electrical Characteristics state DC and AC electrical specifications under particular test conditions which ensure specific performance limits. This assumes that the device is within the Operating Ratings. Specifications are not specified for parameters where no limit is given, however, the typical value is a good indication of device performance.
- (2) If Military/Aerospace specified devices are required, please contact the Texas Instruments Sales Office/Distributors for availability and specifications.
- (3) The maximum junction temperature of the LM3914 is 100°C. Devices must be derated for operation at elevated temperatures. Junction to ambient thermal resistance is 55°C/W for the PDIP (NFK package).
- (4) Pin 5 input current must be limited to ±3mA. The addition of a 39k resistor in series with pin 5 allows ±100V signals without damage.

ELECTRICAL CHARACTERISTICS⁽¹⁾⁽²⁾

Parameter	Conditions ⁽¹⁾	Min	Typ	Max	Units
COMPARATOR					
Offset Voltage, Buffer and First Comparator	$0V \leq V_{RLO} = V_{RHI} \leq 12V$, $I_{LED} = 1 \text{ mA}$		3	10	mV
Offset Voltage, Buffer and Any Other Comparator	$0V \leq V_{RLO} = V_{RHI} \leq 12V$, $I_{LED} = 1 \text{ mA}$		3	15	mV
Gain ($\Delta I_{LED}/\Delta V_{IN}$)	$I_{L(REF)} = 2 \text{ mA}$, $I_{LED} = 10 \text{ mA}$	3	8		mA/mV
Input Bias Current (at Pin 5)	$0V \leq V_{IN} \leq V^+ - 1.5V$		25	100	nA
Input Signal Overvoltage	No Change in Display	–35		35	V
VOLTAGE-DIVIDER					
Divider Resistance	Total, Pin 6 to 4	8	12	17	kΩ
Accuracy	⁽³⁾		0.5	2	%

- (1) Unless otherwise stated, all specifications apply with the following conditions:
 $3 V_{DC} \leq V^+ \leq 20 V_{DC}$ $V_{REF}, V_{RHI}, V_{RLO} \leq (V^+ - 1.5V)$
 $3 V_{DC} \leq V_{LED} \leq V^+$ $0V \leq V_{IN} \leq V^+ - 1.5V$
 $-0.015V \leq V_{RLO} \leq 12V_{DC}$ $T_A = +25^\circ\text{C}$, $I_{L(REF)} = 0.2 \text{ mA}$, $V_{LED} = 3.0V$, pin 9 connected to pin 3 (Bar Mode).
 $-0.015V \leq V_{RHI} \leq 12 V_{DC}$ For higher power dissipations, pulse testing is used.
- (2) Pin 5 input current must be limited to ±3mA. The addition of a 39k resistor in series with pin 5 allows ±100V signals without damage.
- (3) Accuracy is measured referred to +10.000V_{DC} at pin 6, with 0.000 V_{DC} at pin 4. At lower full-scale voltages, buffer and comparator offset voltage may add significant error.

ELECTRICAL CHARACTERISTICS⁽¹⁾⁽²⁾ (continued)

Parameter	Conditions ⁽¹⁾	Min	Typ	Max	Units	
VOLTAGE REFERENCE						
Output Voltage	$0.1 \text{ mA} \leq I_{L(\text{REF})} \leq 4 \text{ mA}$, $V^+ = V_{\text{LED}} = 5\text{V}$	1.2	1.28	1.34	V	
Line Regulation	$3\text{V} \leq V^+ \leq 18\text{V}$		0.01	0.03	%/V	
Load Regulation	$0.1 \text{ mA} \leq I_{L(\text{REF})} \leq 4 \text{ mA}$, $V^+ = V_{\text{LED}} = 5\text{V}$		0.4	2	%	
Output Voltage Change with Temperature	$0^\circ\text{C} \leq T_A \leq +70^\circ\text{C}$, $I_{L(\text{REF})} = 1 \text{ mA}$, $V^+ = 5\text{V}$		1		%	
Adjust Pin Current			75	120	μA	
OUTPUT DRIVERS						
LED Current	$V^+ = V_{\text{LED}} = 5\text{V}$, $I_{L(\text{REF})} = 1 \text{ mA}$	7	10	13	mA	
LED Current Difference (Between Largest and Smallest LED Currents)	$V_{\text{LED}} = 5\text{V}$	$I_{\text{LED}} = 2 \text{ mA}$		0.12	0.4	mA
		$I_{\text{LED}} = 20 \text{ mA}$		1.2	3	
LED Current Regulation	$2\text{V} \leq V_{\text{LED}} \leq 17\text{V}$	$I_{\text{LED}} = 2 \text{ mA}$		0.1	0.25	mA
		$I_{\text{LED}} = 20 \text{ mA}$		1	3	
Dropout Voltage	$I_{\text{LED}(\text{ON})} = 20 \text{ mA}$, $V_{\text{LED}} = 5\text{V}$, $\Delta I_{\text{LED}} = 2 \text{ mA}$			1.5	V	
Saturation Voltage	$I_{\text{LED}} = 2.0 \text{ mA}$, $I_{L(\text{REF})} = 0.4 \text{ mA}$		0.15	0.4	V	
Output Leakage, Each Collector	(Bar Mode) ⁽⁴⁾		0.1	10	μA	
Output Leakage	(Dot Mode) ⁽⁴⁾	Pins 10–18		0.1	10	μA
		Pin 1	60	150	450	μA
SUPPLY CURRENT						
Standby Supply Current (All Outputs Off)	$V^+ = 5\text{V}$, $I_{L(\text{REF})} = 0.2 \text{ mA}$		2.4	4.2	mA	
	$V^+ = 20\text{V}$, $I_{L(\text{REF})} = 1.0 \text{ mA}$		6.1	9.2	mA	

(4) Bar mode results when pin 9 is within 20mV of V^+ . Dot mode results when pin 9 is pulled at least 200mV below V^+ or left open circuit. LED No. 10 (pin 10 output current) is disabled if pin 9 is pulled 0.9V or more below V_{LED} .

DEFINITION OF TERMS

Accuracy: The difference between the observed threshold voltage and the ideal threshold voltage for each comparator. Specified and tested with 10V across the internal voltage divider so that resistor ratio matching error predominates over comparator offset voltage.

Adjust Pin Current: Current flowing out of the reference adjust pin when the reference amplifier is in the linear region.

Comparator Gain: The ratio of the change in output current (I_{LED}) to the change in input voltage (V_{IN}) required to produce it for a comparator in the linear region.

Dropout Voltage: The voltage measured at the current source outputs required to make the output current fall by 10%.

Input Bias Current: Current flowing out of the signal input when the input buffer is in the linear region.

LED Current Regulation: The change in output current over the specified range of LED supply voltage (V_{LED}) as measured at the current source outputs. As the forward voltage of an LED does not change significantly with a small change in forward current, this is equivalent to changing the voltage at the LED anodes by the same amount.

Line Regulation: The average change in reference output voltage over the specified range of supply voltage (V^+).

Load Regulation: The change in reference output voltage (V_{REF}) over the specified range of load current ($I_{L(REF)}$).

Offset Voltage: The differential input voltage which must be applied to each comparator to bias the output in the linear region. Most significant error when the voltage across the internal voltage divider is small. Specified and tested with pin 6 voltage (V_{RHI}) equal to pin 4 voltage (V_{RLO}).

TYPICAL PERFORMANCE CHARACTERISTICS

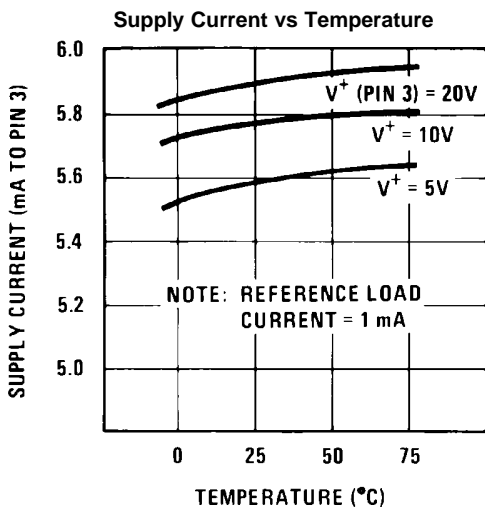

Figure 2.

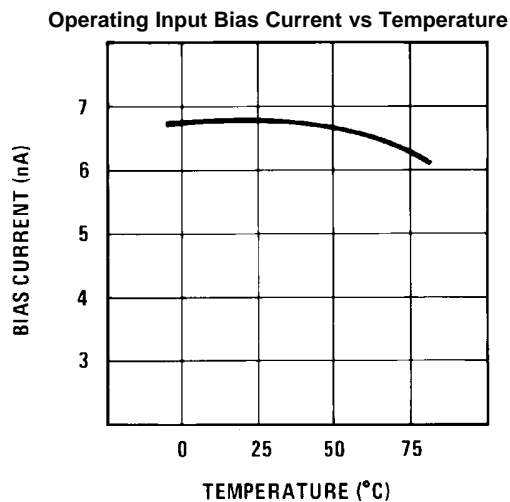

Figure 3.

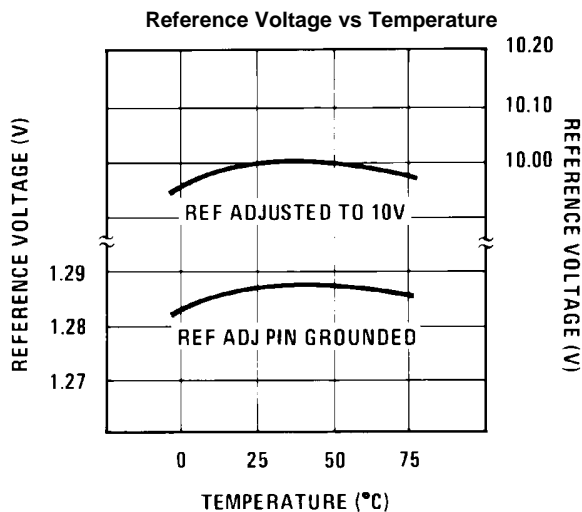

Figure 4.

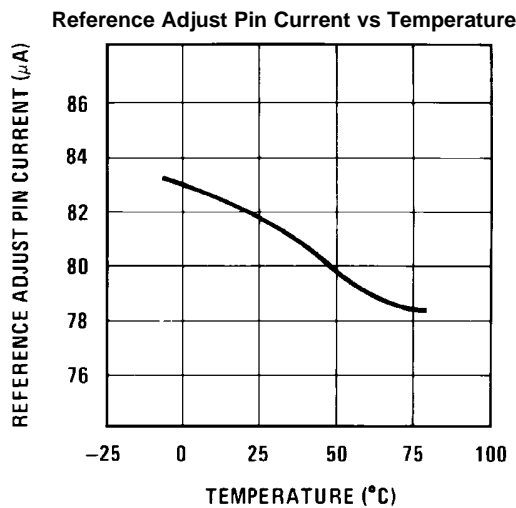

Figure 5.

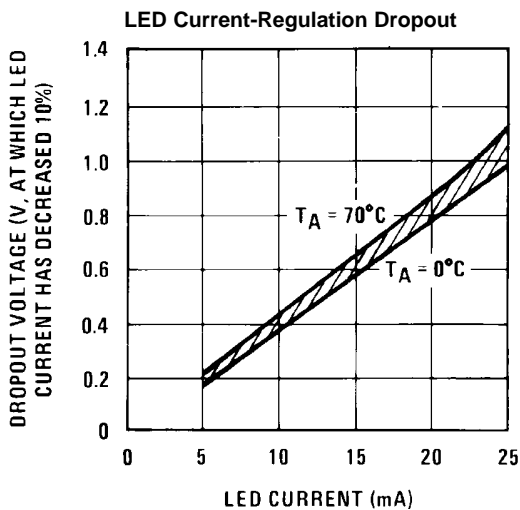

Figure 6.

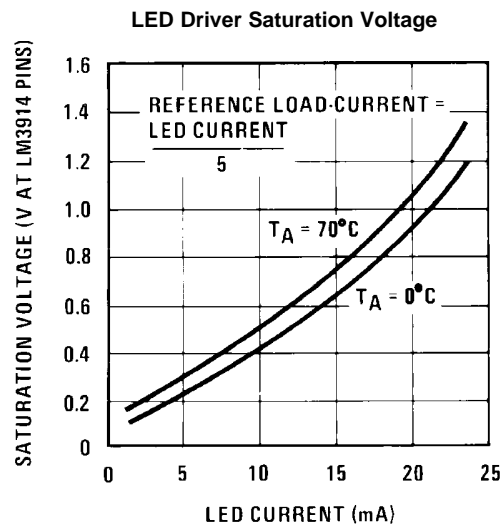

Figure 7.

TYPICAL PERFORMANCE CHARACTERISTICS (continued)



Figure 8.

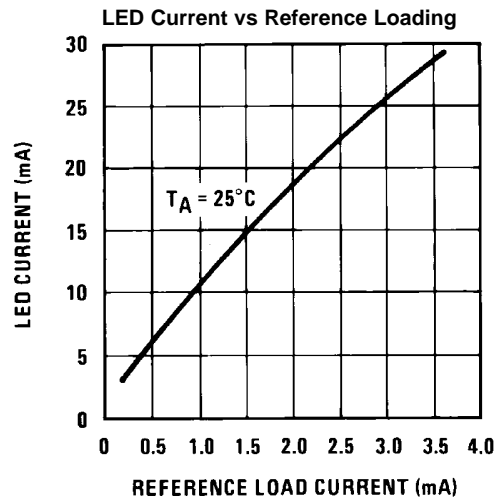

Figure 9.



Figure 10.

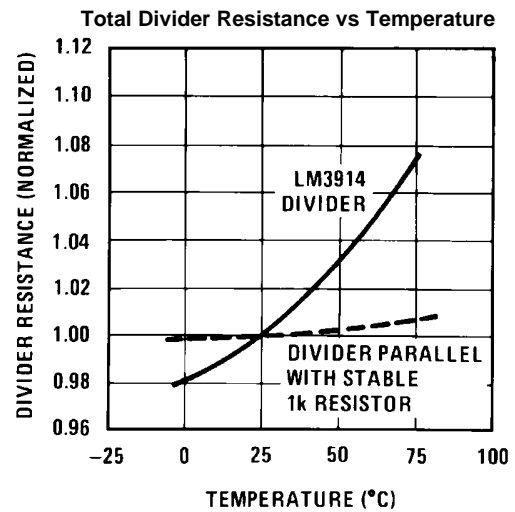

Figure 11.



Figure 12.

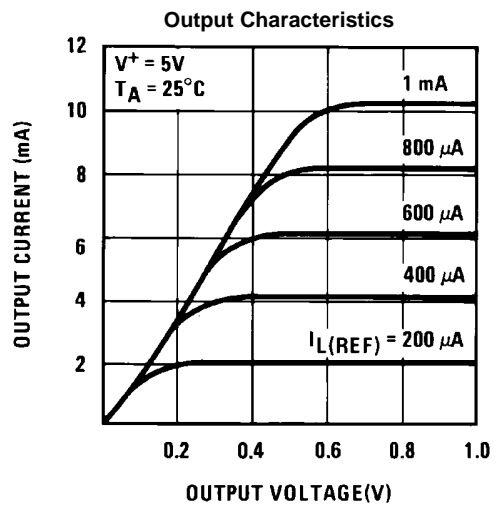
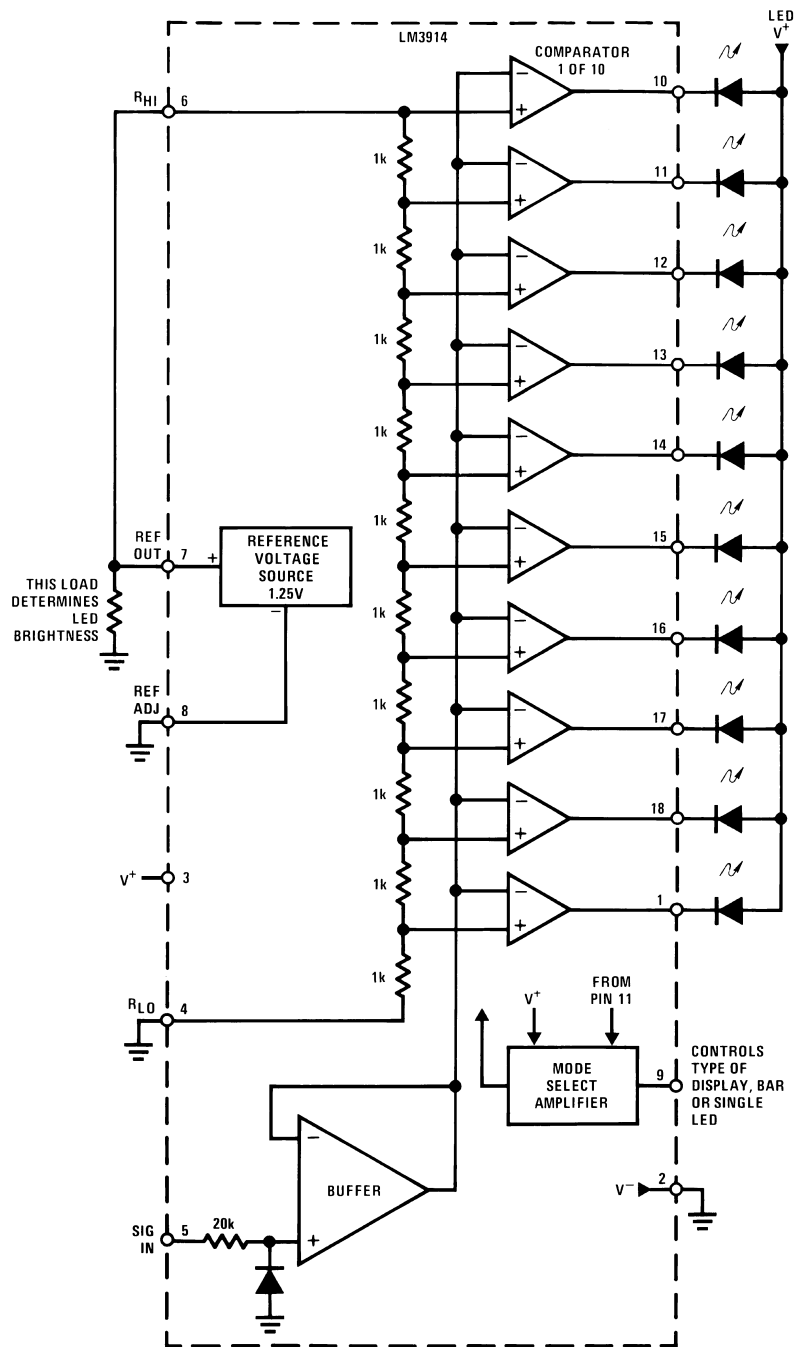

Figure 13.

BLOCK DIAGRAM

(Showing Simplest Application)



FUNCTIONAL DESCRIPTION

The simplified LM3914 block diagram is to give the general idea of the circuit's operation. A high input impedance buffer operates with signals from ground to 12V, and is protected against reverse and overvoltage signals. The signal is then applied to a series of 10 comparators; each of which is biased to a different comparison level by the resistor string.

In the example illustrated, the resistor string is connected to the internal 1.25V reference voltage. In this case, for each 125mV that the input signal increases, a comparator will switch on another indicating LED. This resistor divider can be connected between any 2 voltages, providing that they are 1.5V below V^+ and no less than V^- . If an expanded scale meter display is desired, the total divider voltage can be as little as 200mV. Expanded-scale meter displays are more accurate and the segments light uniformly only if bar mode is used. At 50mV or more per step, dot mode is usable.

INTERNAL VOLTAGE REFERENCE

The reference is designed to be adjustable and develops a nominal 1.25V between the REF OUT (pin 7) and REF ADJ (pin 8) terminals. The reference voltage is impressed across program resistor R1 and, since the voltage is constant, a constant current I_1 then flows through the output set resistor R2 giving an output voltage of:

$$V_{OUT} = V_{REF} \left(1 + \frac{R_2}{R_1} \right) + I_{ADJ} R_2$$

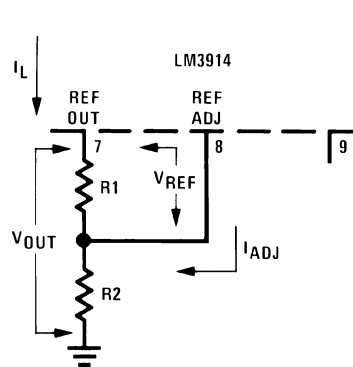

Since the 120 μ A current (max) from the adjust terminal represents an error term, the reference was designed to minimize changes of this current with V^+ and load changes.

CURRENT PROGRAMMING

A feature not completely illustrated by the block diagram is the LED brightness control. The current drawn out of the reference voltage pin (pin 7) determines LED current. Approximately 10 times this current will be drawn through each lighted LED, and this current will be relatively constant despite supply voltage and temperature changes. Current drawn by the internal 10-resistor divider, as well as by the external current and voltage-setting divider should be included in calculating LED drive current. The ability to modulate LED brightness with time, or in proportion to input voltage and other signals can lead to a number of novel displays or ways of indicating input overvoltages, alarms, etc.

MODE PIN USE

Pin 9, the Mode Select input controls chaining of multiple LM3914s, and controls bar or dot mode operation. The following tabulation shows the basic ways of using this input. Other more complex uses will be illustrated in the applications.

Bar Graph Display: Wire Mode Select (pin 9) *directly* to pin 3 (V^+ pin).

Dot Display, Single LM3914 Driver: Leave the Mode Select pin open circuit.

Dot Display, 20 or More LEDs: Connect pin 9 of the *first* driver in the series (i.e., the one with the lowest input voltage comparison points) to pin 1 of the next higher LM3914 driver. Continue connecting pin 9 of lower input drivers to pin 1 of higher input drivers for 30, 40, or more LED displays. The last LM3914 driver in the chain will have pin 9 wired to pin 11. All previous drivers should have a 20k resistor in parallel with LED No. 9 (pin 11 to V_{LED}).

MODE PIN FUNCTIONAL DESCRIPTION

This pin actually performs two functions. Refer to the [simplified block diagram](#) below.

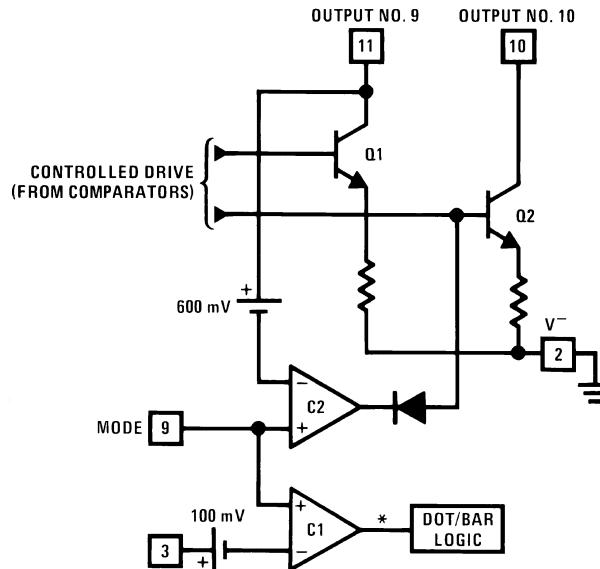

*High for bar

Figure 14. Block Diagram of Mode Pin Description

DOT OR BAR MODE SELECTION

The voltage at pin 9 is sensed by comparator C1, nominally referenced to ($V^+ - 100\text{mV}$). The chip is in bar mode when pin 9 is above this level; otherwise it's in dot mode. The comparator is designed so that pin 9 can be left open circuit for dot mode.

Taking into account comparator gain and variation in the 100mV reference level, pin 9 should be no more than 20mV below V^+ for bar mode and more than 200mV below V^+ (or open circuit) for dot mode. In most applications, pin 9 is either open (dot mode) or tied to V^+ (bar mode). In bar mode, pin 9 should be connected directly to pin 3. Large currents drawn from the power supply (LED current, for example) should not share this path so that large IR drops are avoided.

DOT MODE CARRY

In order for the display to make sense when multiple LM3914s are cascaded in dot mode, special circuitry has been included to shut off LED No. 10 of the first device when LED No. 1 of the second device comes on. The connection for cascading in dot mode has already been described and is depicted below.

As long as the input signal voltage is below the threshold of the second LM3914, LED No. 11 is off. Pin 9 of LM3914 No. 1 thus sees effectively an open circuit so the chip is in dot mode. As soon as the input voltage reaches the threshold of LED No. 11, pin 9 of LM3914 No. 1 is pulled an LED drop (1.5V or more) below V_{LED} . This condition is sensed by comparator C2, referenced 600mV below V_{LED} . This forces the output of C2 low, which shuts off output transistor Q2, extinguishing LED No. 10.

V_{LED} is sensed via the 20k resistor connected to pin 11. The very small current (less than 100 μA) that is diverted from LED No. 9 does not noticeably affect its intensity.

An auxiliary current source at pin 1 keeps at least 100 μA flowing through LED No. 11 even if the input voltage rises high enough to extinguish the LED. This ensures that pin 9 of LM3914 No. 1 is held low enough to force LED No. 10 off when *any* higher LED is illuminated. While 100 μA does not normally produce significant LED illumination, it may be noticeable when using high-efficiency LEDs in a dark environment. If this is bothersome, the simple cure is to shunt LED No. 11 with a 10k resistor. The 1V IR drop is more than the 900mV worst case required to hold off LED No. 10 yet small enough that LED No. 11 does not conduct significantly.

OTHER DEVICE CHARACTERISTICS

The LM3914 is relatively low-powered itself, and since any number of LEDs can be powered from about 3V, it is a very efficient display driver. Typical standby supply current (all LEDs OFF) is 1.6mA (2.5mA max). However, any reference loading adds 4 times that current drain to the V^+ (pin 3) supply input. For example, an LM3914 with a 1mA reference pin load (1.3k), would supply almost 10mA to every LED while drawing only 10mA from its V^+ pin supply. At full-scale, the IC is typically drawing less than 10% of the current supplied to the display.

The display driver does not have built-in hysteresis so that the display does not jump instantly from one LED to the next. Under rapidly changing signal conditions, this cuts down high frequency noise and often an annoying flicker. An “overlap” is built in so that at no time between segments are all LEDs completely OFF in the dot mode. Generally 1 LED fades in while the other fades out over a mV or more of range ⁽¹⁾. The change may be much more rapid between LED No. 10 of one device and LED No. 1 of a *second* device “chained” to the first.

The LM3914 features individually current regulated LED driver transistors. Further internal circuitry detects when any driver transistor goes into saturation, and prevents other circuitry from drawing excess current. This results in the ability of the LM3914 to drive and regulate LEDs powered from a pulsating DC power source, i.e., largely unfiltered. (Due to possible oscillations at low voltages a nominal bypass capacitor consisting of a 2.2 μ F solid tantalum connected from the pulsating LED supply to pin 2 of the LM3914 is recommended.) This ability to operate with low or fluctuating voltages also allows the display driver to interface with logic circuitry, opto-coupled solid-state relays, and low-current incandescent lamps.

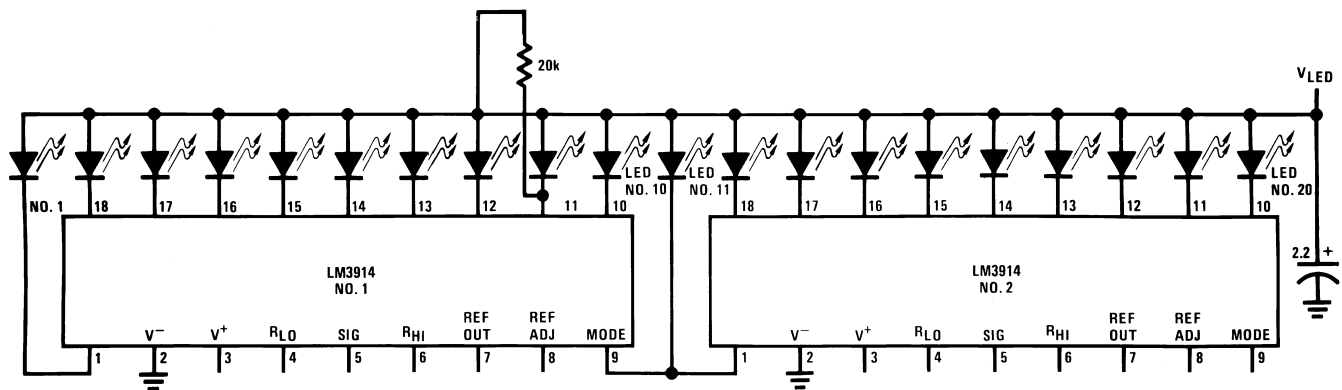

Figure 15. Cascading LM3914s in Dot Mode

(1) Accuracy is measured referred to +10.000V_{DC} at pin 6, with 0.000 V_{DC} at pin 4. At lower full-scale voltages, buffer and comparator offset voltage may add significant error.

Typical Applications

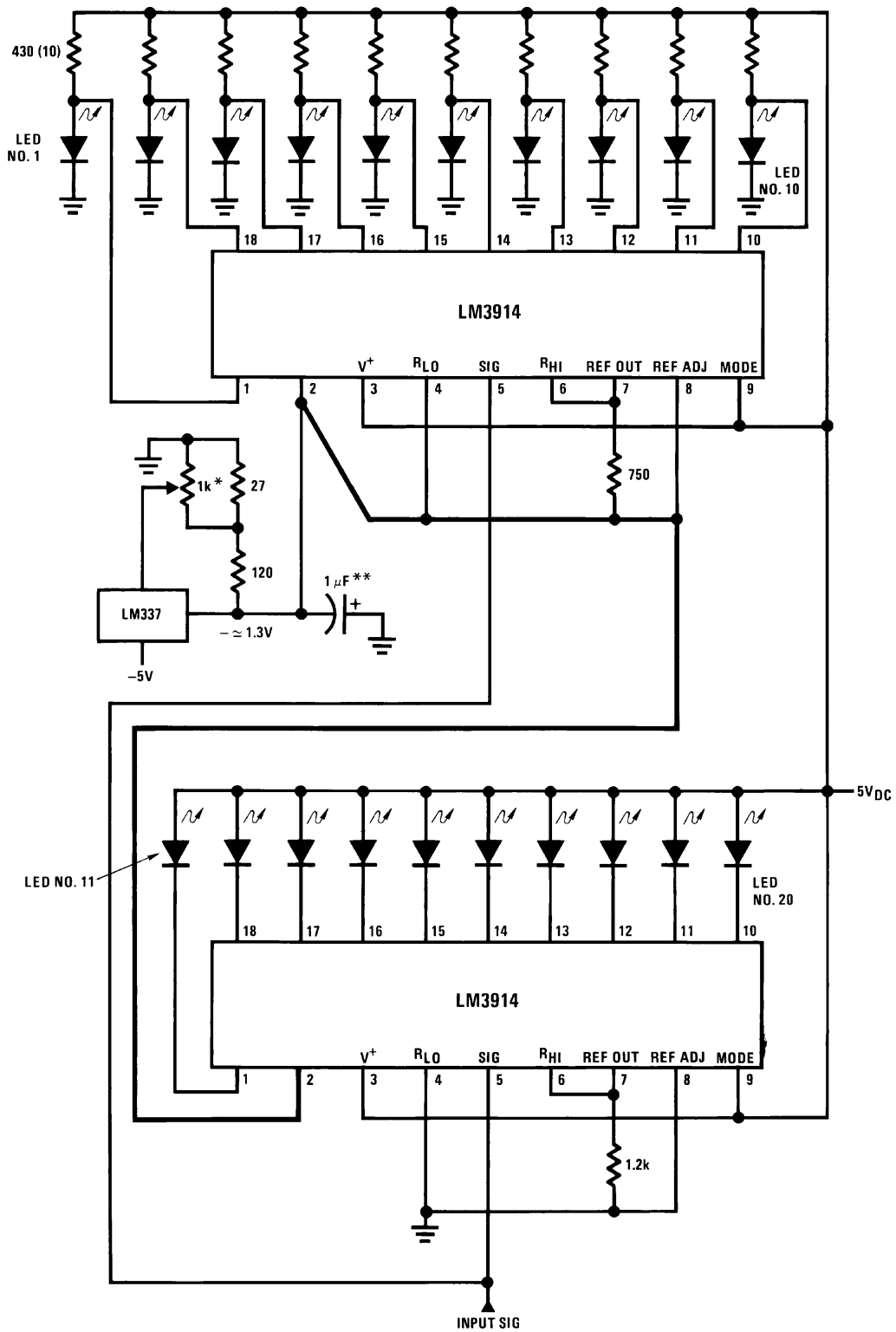
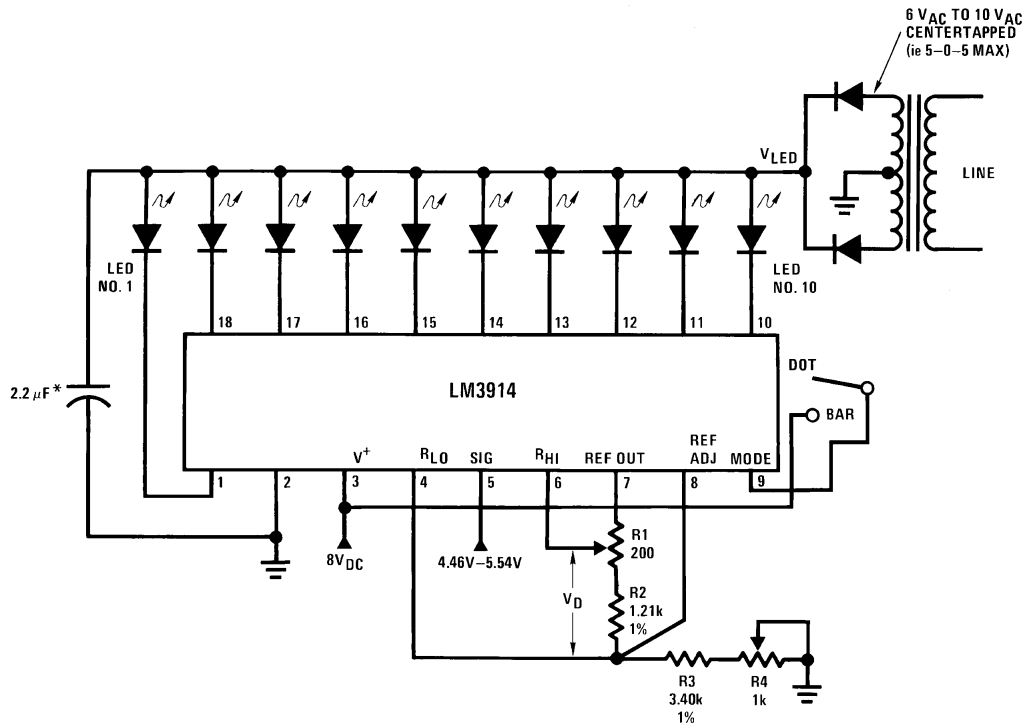

Figure 16. Zero-Center Meter, 20-Segment



*This application illustrates that the LED supply needs practically no filtering
Calibration: With a precision meter between pins 4 and 6 adjust R1 for voltage V_D of 1.20V. Apply 4.94V to pin 5, and adjust R4 until LED No. 5 just lights. The adjustments are non-interacting.

Figure 17. Expanded Scale Meter, Dot or Bar

Table 1. Application Example: Grading 5V Regulators

Highest No. LED on	Color	$V_{OUT(MIN)}$
10	Red	5.54
9	Red	5.42
8	Yellow	5.30
7	Green	5.18
6	Green	5.06
	5V	
5	Green	4.94
4	Green	4.82
3	Yellow	4.7
2	Red	4.58
1	Red	4.46

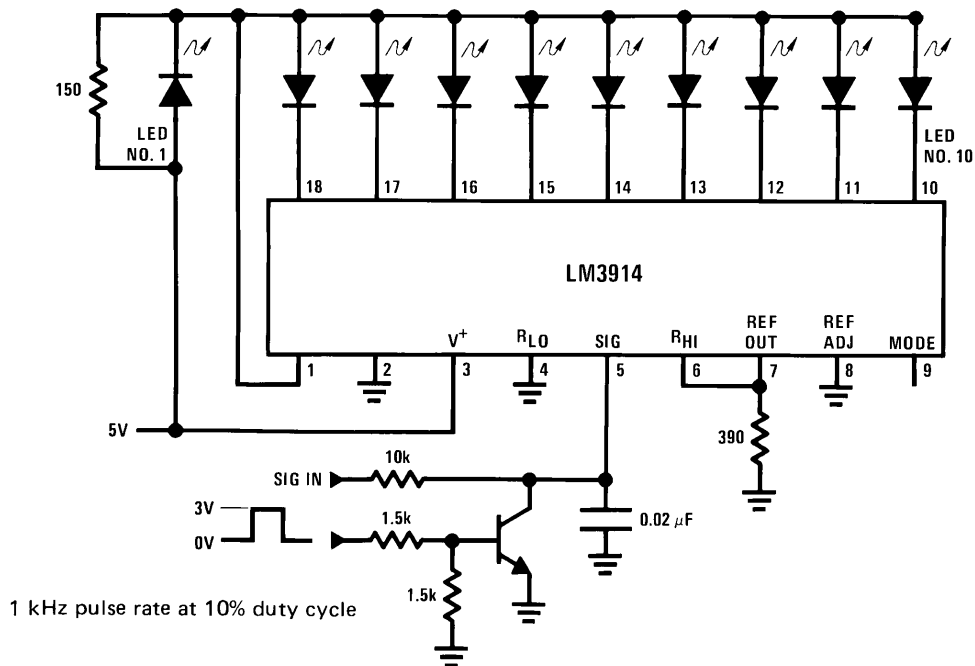

LEDs light up as illustrated with the upper lit LED indicating the actual input voltage. The display appears to increase resolution and provides an analog indication of overrange.

Figure 18. "Exclamation Point" Display

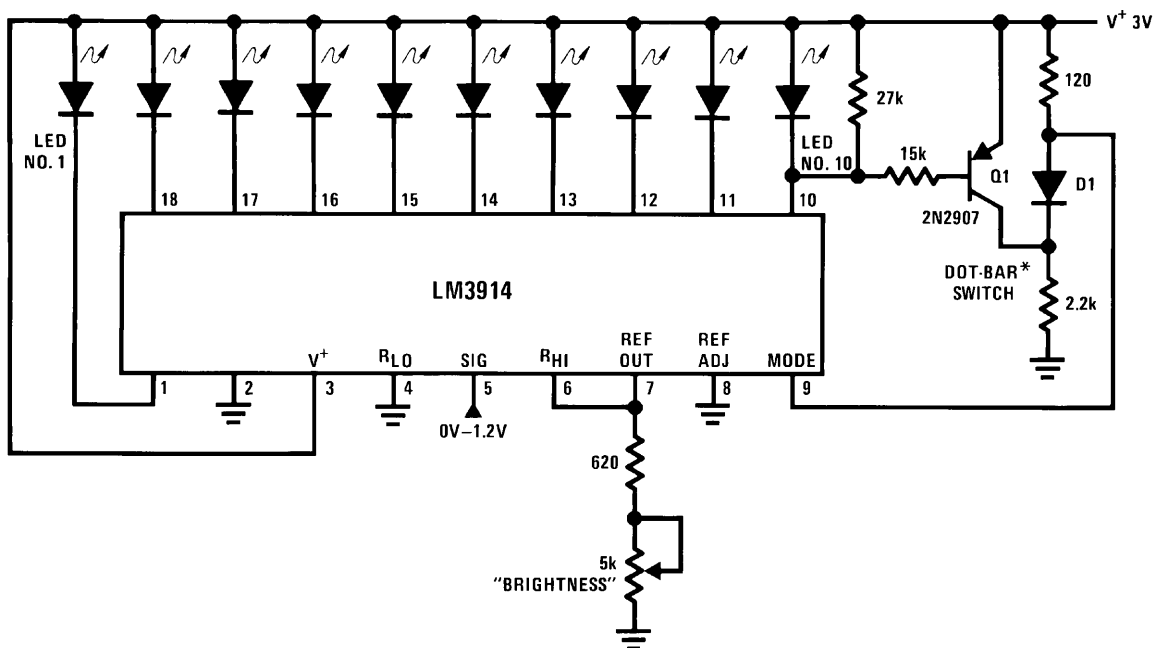

*The input to the Dot-Bar Switch may be taken from cathodes of other LEDs. Display will change to bar as soon as the LED so selected begins to light.

Figure 19. Indicator and Alarm, Full-Scale Changes Display from Dot to Bar

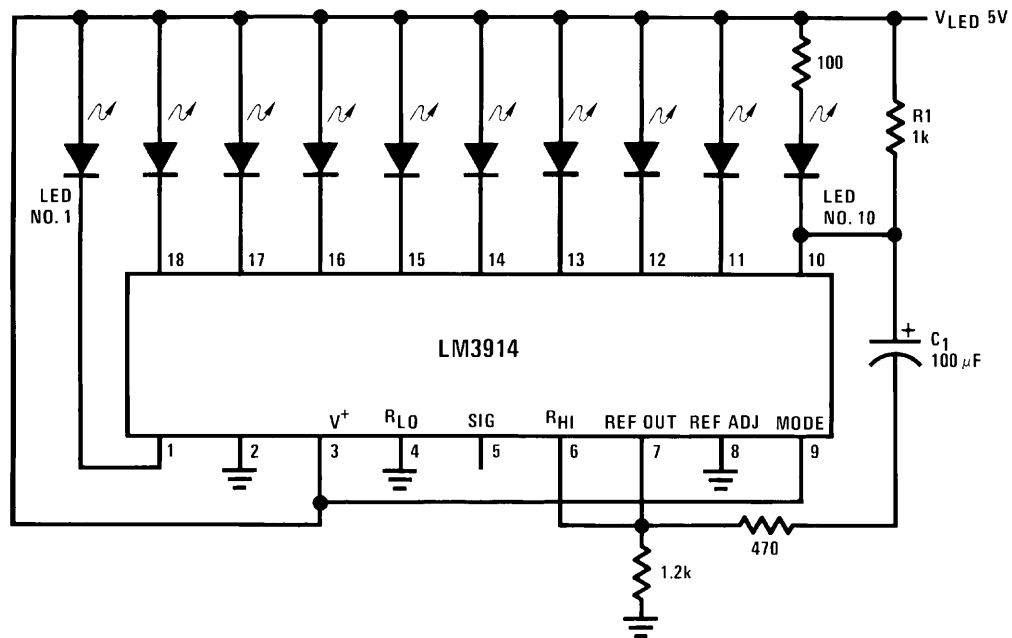

Full-scale causes the full bar display to flash. If the junction of R1 and C1 is connected to a different LED cathode, the display will flash when that LED lights, and at any higher input signal.

Figure 20. Bar Display with Alarm Flasher

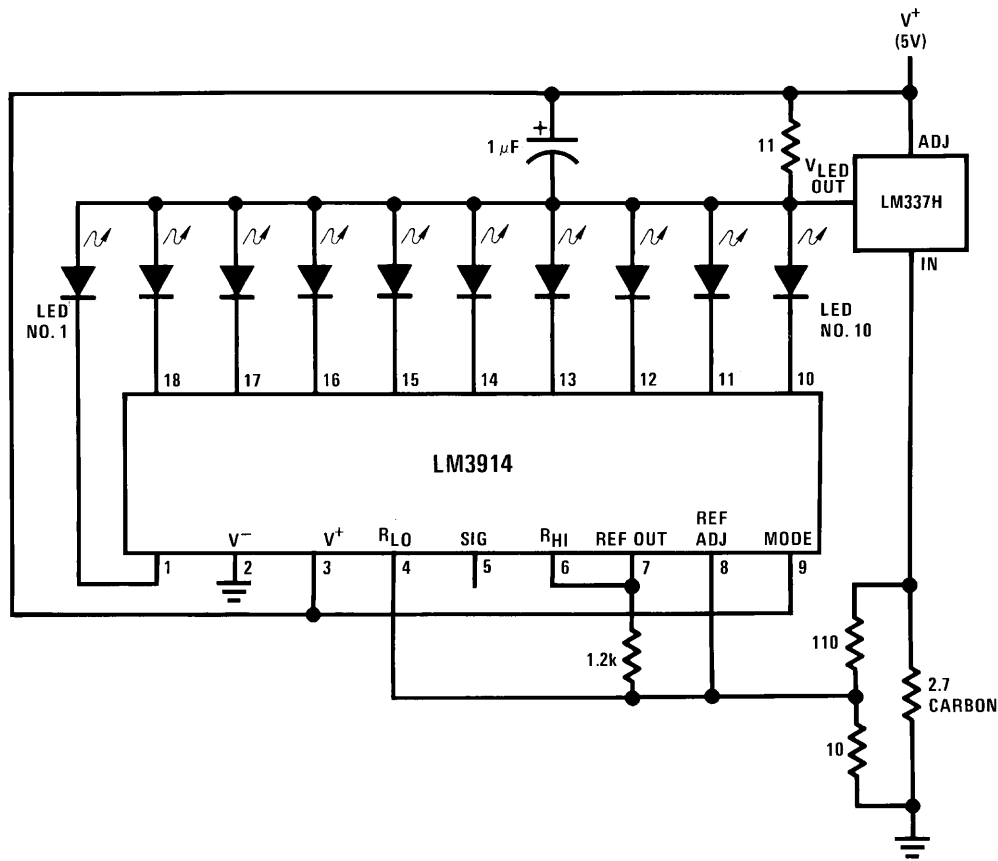

Hysteresis is 0.5 mV to 1 mV

Figure 21. Adding Hysteresis (Single Supply, Bar Mode Only)

Figure 22.

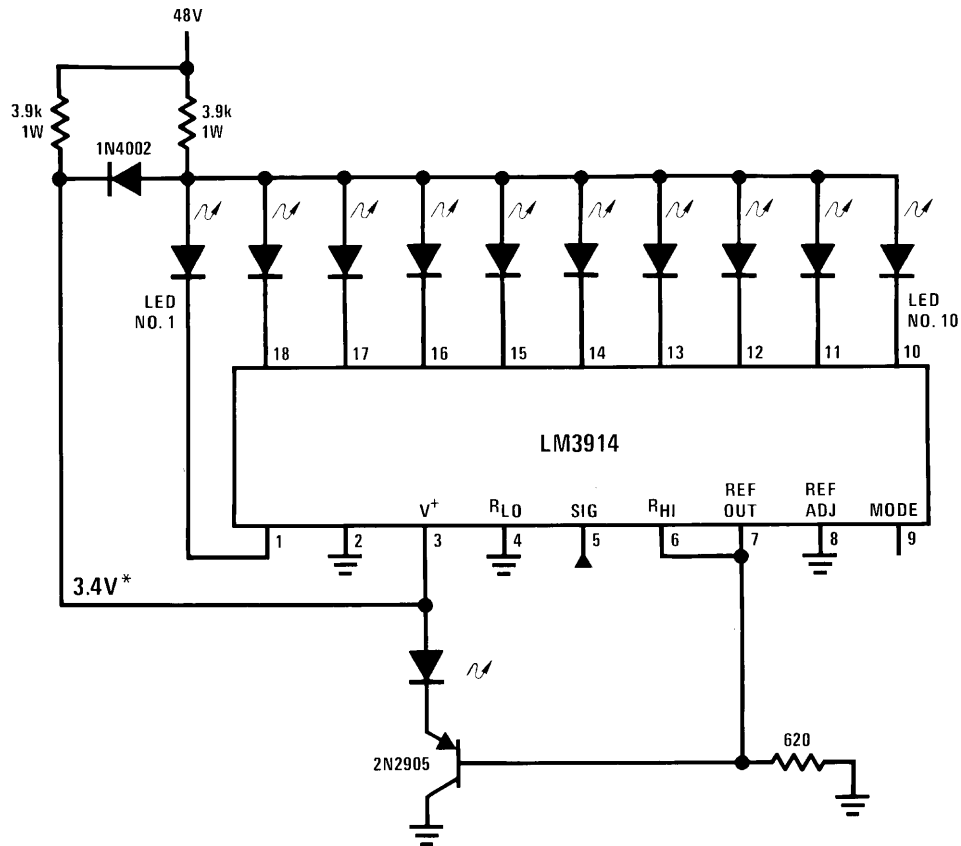

The LED currents are approximately 10mA, and the LM3914 outputs operate in saturation for minimum dissipation.
 *This point is partially regulated and decreases in voltage with temperature. Voltage requirements of the LM3914 also decrease with temperature.

Figure 23. Operating with a High Voltage Supply (Dot Mode Only)

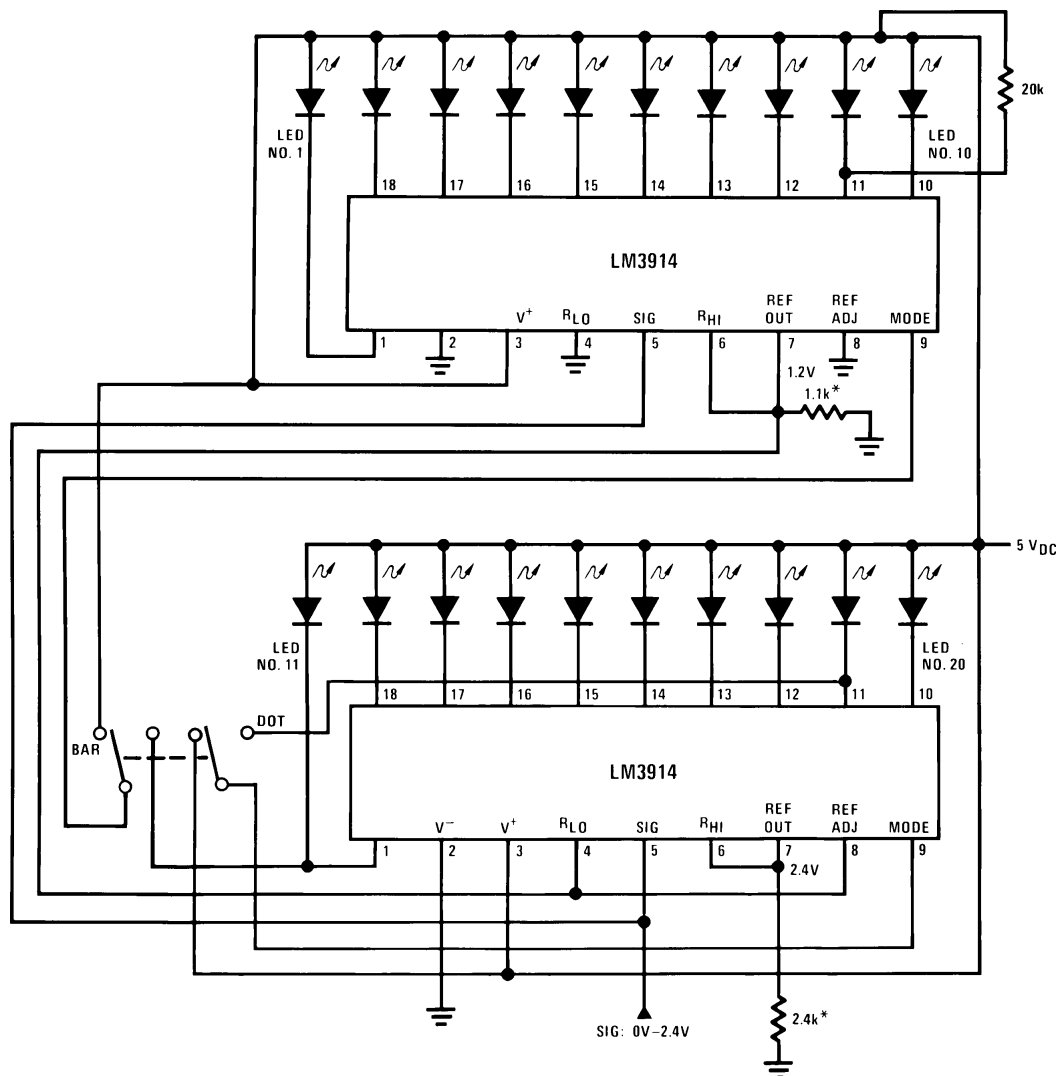

*The exact wiring arrangement of this schematic shows the need for Mode Select (pin 9) to sense the V^+ voltage exactly as it appears on pin 3.
Programs LEDs to 10mA

Figure 24. 20-Segment Meter with Mode Switch

APPLICATION HINTS

Three of the most commonly needed precautions for using the LM3914 are shown in the first typical application drawing showing a 0V–5V bar graph meter. The most difficult problem occurs when large LED currents are being drawn, especially in bar graph mode. These currents flowing out of the ground pin cause voltage drops in external wiring, and thus errors and oscillations. Bringing the return wires from signal sources, reference ground and bottom of the resistor string (as illustrated) to a single point very near pin 2 is the best solution.

Long wires from V_{LED} to LED anode common can cause oscillations. Depending on the severity of the problem 0.05 μ F to 2.2 μ F decoupling capacitors from LED anode common to pin 2 will damp the circuit. If LED anode line wiring is inaccessible, often similar decoupling from pin 1 to pin 2 will be sufficient.

If LED turn ON seems slow (bar mode) or several LEDs light (dot mode), oscillation or excessive noise is usually the problem. In cases where proper wiring and bypassing fail to stop oscillations, V^+ voltage at pin 3 is usually below suggested limits. Expanded scale meter applications may have one or both ends of the internal voltage divider terminated at relatively high value resistors. These high-impedance ends should be bypassed to pin 2 with at least a $0.001\mu\text{F}$ capacitor, or up to $0.1\mu\text{F}$ in noisy environments.

Power dissipation, especially in bar mode should be given consideration. For example, with a 5V supply and all LEDs programmed to 20mA the driver will dissipate over 600mW. In this case a 7.5Ω resistor in series with the LED supply will cut device heating in half. The negative end of the resistor should be bypassed with a $2.2\mu\text{F}$ solid tantalum capacitor to pin 2 of the LM3914.

Turning OFF of most of the internal current sources is accomplished by pulling positive on the reference with a current source or resistance supplying $100\mu\text{A}$ or so. Alternately, the input signal can be gated OFF with a transistor switch.

Other special features and applications characteristics will be illustrated in the following applications schematics. Notes have been added in many cases, attempting to cover any special procedures or unusual characteristics of these applications. A special section called [APPLICATION TIPS FOR THE LM3914 ADJUSTABLE REFERENCE](#) has been included with these schematics.

APPLICATION TIPS FOR THE LM3914 ADJUSTABLE REFERENCE

Greatly Expanded Scale (Bar Mode Only)

Placing the LM3914 internal resistor divider in parallel with a section ($\approx 230\Omega$) of a stable, low resistance divider greatly reduces voltage changes due to IC resistor value changes with temperature. Voltage V_1 should be trimmed to 1.1V first by use of R2. Then the voltage V_2 across the IC divider string can be adjusted to 200mV, using R5 without affecting V_1 . LED current will be approximately 10mA.

Non-Interacting Adjustments For Expanded Scale Meter (4.5V to 5V, Bar or Dot Mode)

This arrangement allows independent adjustment of LED brightness regardless of meter span and zero adjustments.

First, V_1 is adjusted to 5V, using R2. Then the span (voltage across R4) can be adjusted to exactly 0.5V using R6 without affecting the previous adjustment.

R9 programs LED currents within a range of 2.2mA to 20mA after the above settings are made.

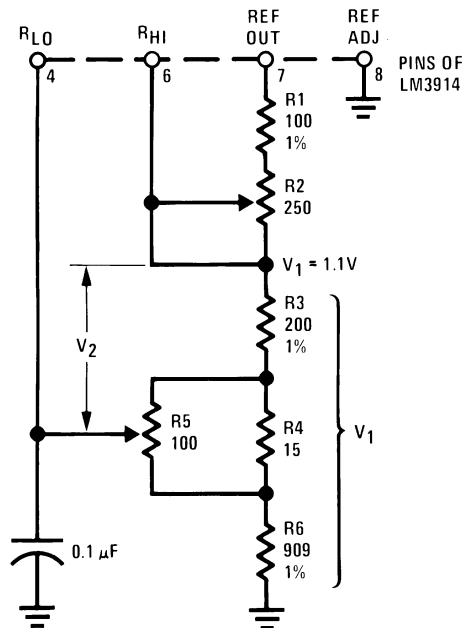

Figure 25. Greatly Expanded Scale (Bar Mode Only)

ADJUSTING LINEARITY OF SEVERAL STACKED DIVIDERS

Three internal voltage dividers are shown connected in series to provide a 30-step display. If the resulting analog meter is to be accurate and linear the voltage on each divider must be adjusted, preferably without affecting any other adjustments. To do this, adjust R2 first, so that the voltage across R5 is exactly 1V. Then the voltages across R3 and R4 can be independently adjusted by shunting each with selected resistors of 6k Ω or higher resistance. This is possible because the reference of LM3914 No. 3 is acting as a constant current source.

The references associated with LM3914s No. 1 and No. 2 should have their Ref Adj pins (pin 8) wired to ground, and their Ref Outputs loaded by a 620 Ω resistor to ground. This makes available similar 20mA current outputs to all the LEDs in the system.

If an independent LED brightness control is desired (as in the previous application), a unity gain buffer, such as the LM310, should be placed between pin 7 and R1, similar to the previous application.

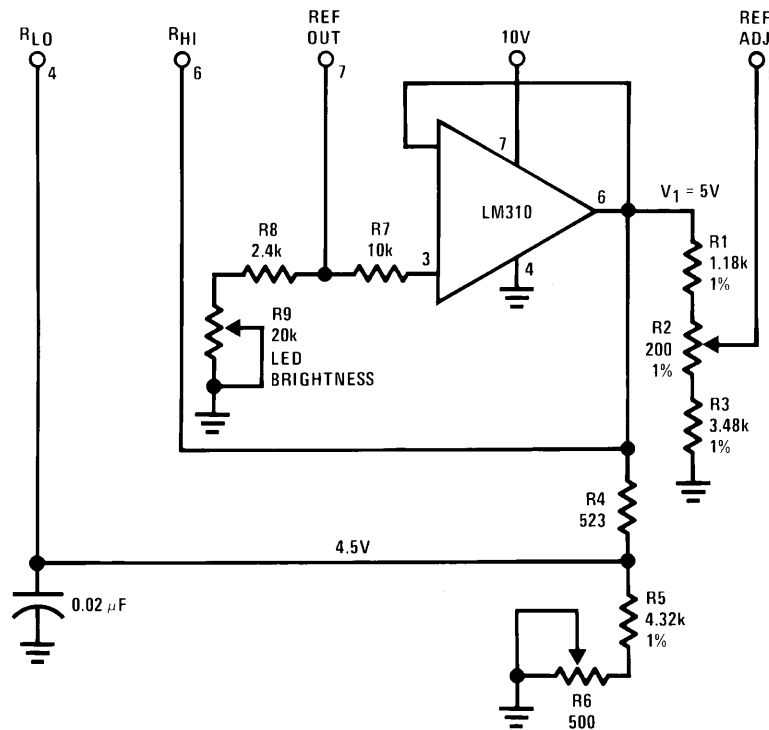

(4.5V to 5V, Bar or Dot Mode)

Figure 26. Non-Interacting Adjustments for Expanded Scale Meter

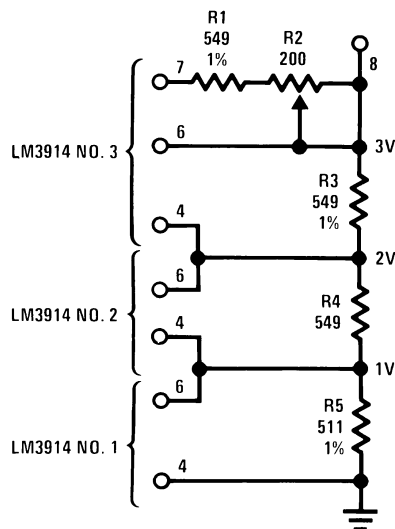
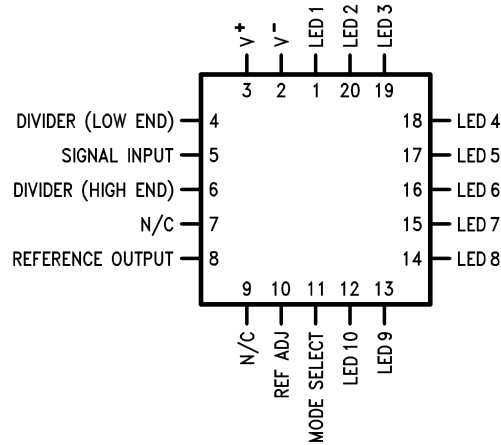

Figure 27. Adjusting Linearity of Several Stacked Dividers

OTHER APPLICATIONS

- “Slow”—fade bar or dot display (doubles resolution)
- 20-step meter with single pot brightness control
- 10-step (or multiples) programmer
- Multi-step or “staging” controller
- Combined controller and process deviation meter
- Direction and rate indicator (to add to DVMs)
- Exclamation point display for power saving
- Graduations can be added to dot displays. Dimly light every other LED using a resistor to ground
- Electronic “meter-relay”—display could be circle or semi-circle
- Moving “hole” display—indicator LED is dark, rest of bar lit
- Drives vacuum-fluorescent and LCDs using added passive parts

CONNECTION DIAGRAM



**Figure 28. Top View
PLCC Package
See Package Number FN0020A**

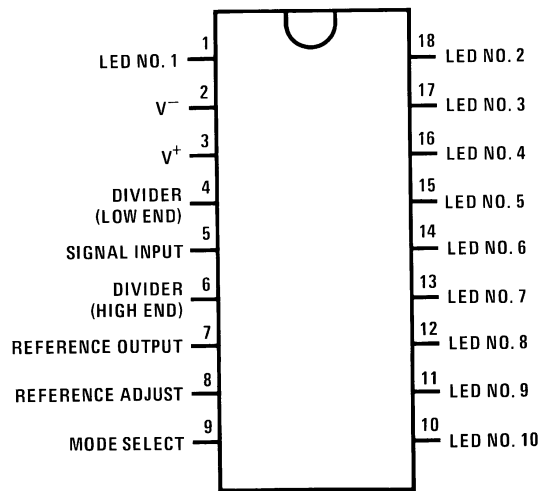

**Figure 29. PDIP Package
Top View
See Package Number NFK0018A**

LM3914 MDC MWC DOT/BAR DISPLAY DRIVER

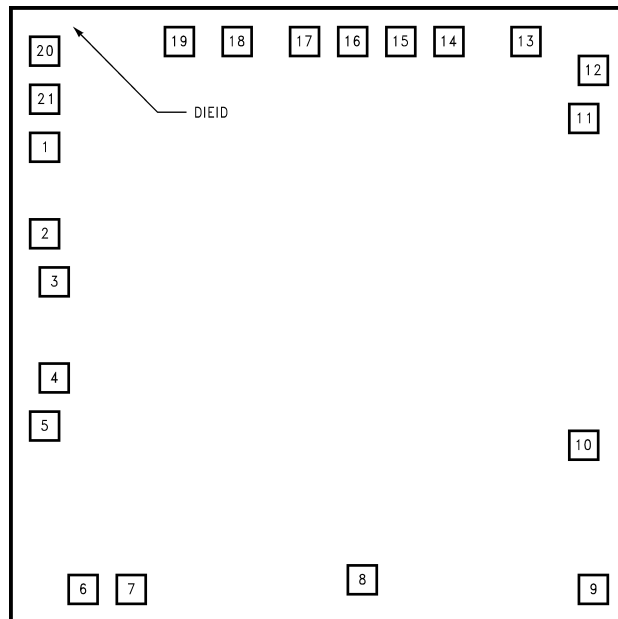

Figure 30. Die Layout (D - Step)

REVISION HISTORY

Changes from Revision A (March 2013) to Revision B	Page
• Changed layout of National Data Sheet to TI format	23

PACKAGING INFORMATION

Orderable Device	Status (1)	Package Type	Package Drawing	Pins	Package Qty	Eco Plan (2)	Lead/Ball Finish (6)	MSL Peak Temp (3)	Op Temp (°C)	Device Marking (4/5)	Samples
LM3914V/NOPB	ACTIVE	PLCC	FN	20	40	Green (RoHS & no Sb/Br)	SN	Level-2A-250C-4 WEEK	0 to 70	LM3914V	Samples
LM3914VX/NOPB	ACTIVE	PLCC	FN	20	1000	Green (RoHS & no Sb/Br)	SN	Level-2A-250C-4 WEEK	0 to 70	LM3914V	Samples

(1) The marketing status values are defined as follows:

ACTIVE: Product device recommended for new designs.

LIFEBUY: TI has announced that the device will be discontinued, and a lifetime-buy period is in effect.

NRND: Not recommended for new designs. Device is in production to support existing customers, but TI does not recommend using this part in a new design.

PREVIEW: Device has been announced but is not in production. Samples may or may not be available.

OBSELETE: TI has discontinued the production of the device.

(2) **RoHS:** TI defines "RoHS" to mean semiconductor products that are compliant with the current EU RoHS requirements for all 10 RoHS substances, including the requirement that RoHS substance do not exceed 0.1% by weight in homogeneous materials. Where designed to be soldered at high temperatures, "RoHS" products are suitable for use in specified lead-free processes. TI may reference these types of products as "Pb-Free".

RoHS Exempt: TI defines "RoHS Exempt" to mean products that contain lead but are compliant with EU RoHS pursuant to a specific EU RoHS exemption.

Green: TI defines "Green" to mean the content of Chlorine (Cl) and Bromine (Br) based flame retardants meet JS709B low halogen requirements of <=1000ppm threshold. Antimony trioxide based flame retardants must also meet the <=1000ppm threshold requirement.

(3) MSL, Peak Temp. - The Moisture Sensitivity Level rating according to the JEDEC industry standard classifications, and peak solder temperature.

(4) There may be additional marking, which relates to the logo, the lot trace code information, or the environmental category on the device.

(5) Multiple Device Markings will be inside parentheses. Only one Device Marking contained in parentheses and separated by a "-" will appear on a device. If a line is indented then it is a continuation of the previous line and the two combined represent the entire Device Marking for that device.

(6) Lead/Ball Finish - Orderable Devices may have multiple material finish options. Finish options are separated by a vertical ruled line. Lead/Ball Finish values may wrap to two lines if the finish value exceeds the maximum column width.

Important Information and Disclaimer:The information provided on this page represents TI's knowledge and belief as of the date that it is provided. TI bases its knowledge and belief on information provided by third parties, and makes no representation or warranty as to the accuracy of such information. Efforts are underway to better integrate information from third parties. TI has taken and continues to take reasonable steps to provide representative and accurate information but may not have conducted destructive testing or chemical analysis on incoming materials and chemicals. TI and TI suppliers consider certain information to be proprietary, and thus CAS numbers and other limited information may not be available for release.

In no event shall TI's liability arising out of such information exceed the total purchase price of the TI part(s) at issue in this document sold by TI to Customer on an annual basis.

FN 20

GENERIC PACKAGE VIEW

PLCC - 4.57 mm max height

PLASTIC CHIP CARRIER

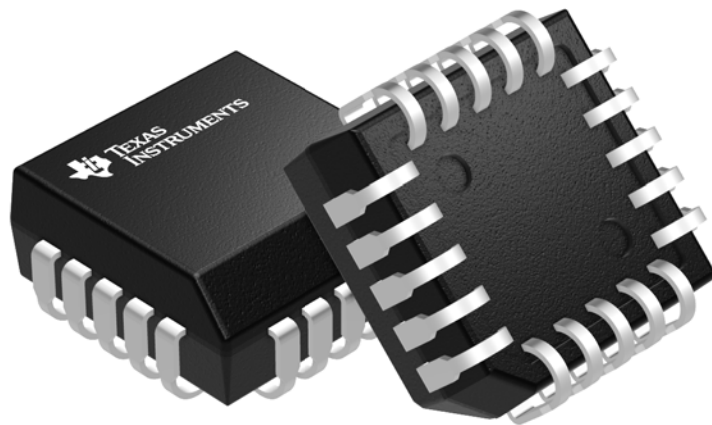

Images above are just a representation of the package family, actual package may vary.
Refer to the product data sheet for package details.

4040005-2/C



FN0020A

PACKAGE OUTLINE PLCC - 4.57 mm max height

PLASTIC CHIP CARRIER

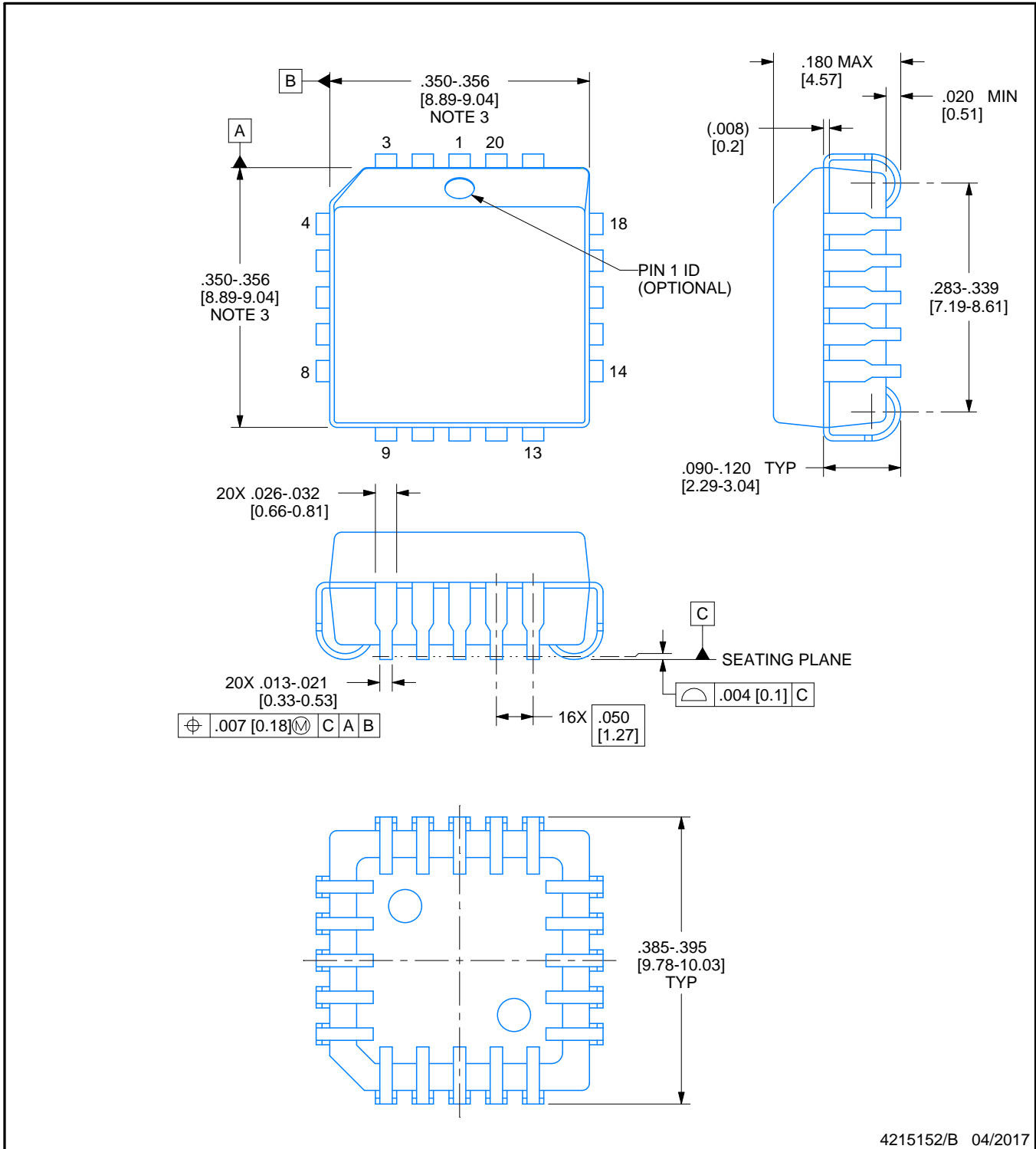

4215152/B 04/2017

NOTES:

1. All linear dimensions are in inches. Any dimensions in brackets are in millimeters. Any dimensions in parenthesis are for reference only. Controlling dimensions are in inches. Dimensioning and tolerancing per ASME Y14.5M.
2. This drawing is subject to change without notice.
3. Dimension does not include mold protrusion. Maximum allowable mold protrusion .01 in [0.25 mm] per side.
4. Reference JEDEC registration MS-018.

EXAMPLE BOARD LAYOUT

FN0020A

PLCC - 4.57 mm max height

PLASTIC CHIP CARRIER

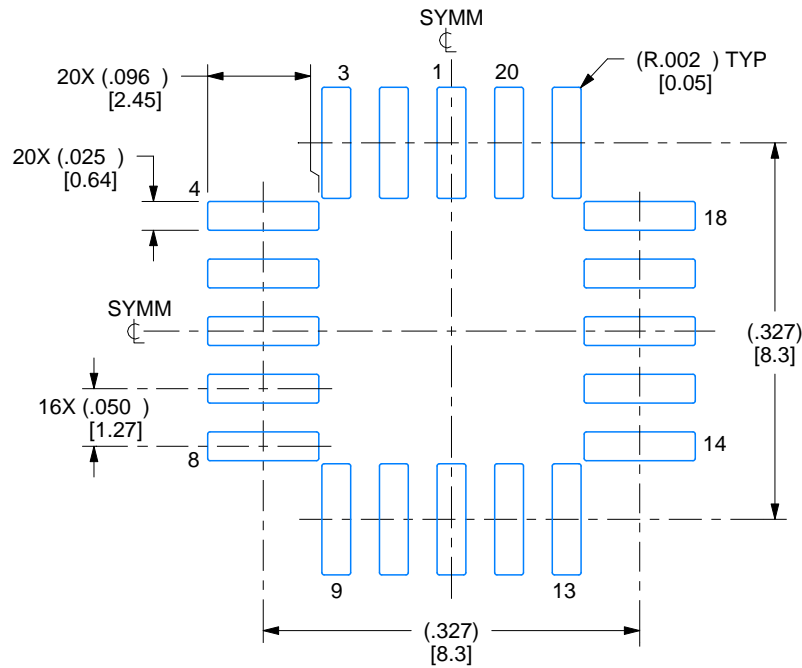

LAND PATTERN EXAMPLE
EXPOSED METAL SHOWN
SCALE:6X

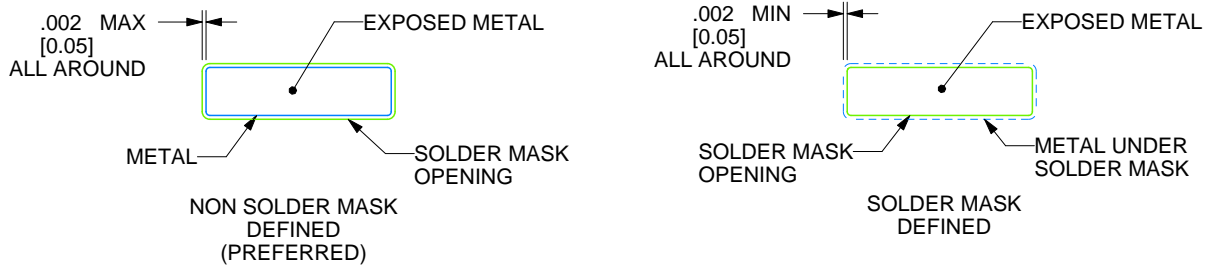

SOLDER MASK DETAILS

4215152/B 04/2017

NOTES: (continued)

- Publication IPC-7351 may have alternate designs.
- Solder mask tolerances between and around signal pads can vary based on board fabrication site.

EXAMPLE STENCIL DESIGN

FN0020A

PLCC - 4.57 mm max height

PLASTIC CHIP CARRIER

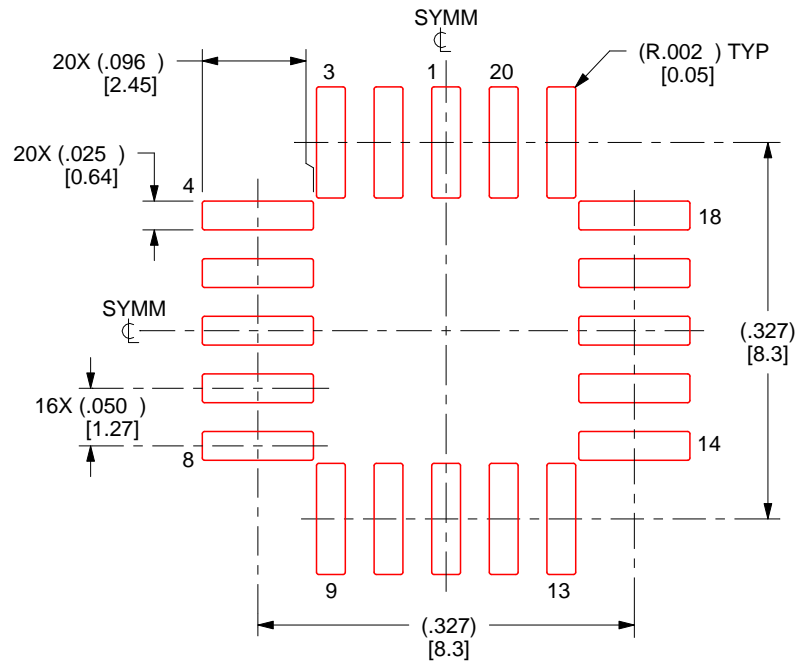

SOLDER PASTE EXAMPLE
BASED ON 0.125 mm THICK STENCIL
SCALE:6X

4215152/B 04/2017

NOTES: (continued)

7. Laser cutting apertures with trapezoidal walls and rounded corners may offer better paste release. IPC-7525 may have alternate design recommendations.
8. Board assembly site may have different recommendations for stencil design.

IMPORTANT NOTICE AND DISCLAIMER

TI PROVIDES TECHNICAL AND RELIABILITY DATA (INCLUDING DATASHEETS), DESIGN RESOURCES (INCLUDING REFERENCE DESIGNS), APPLICATION OR OTHER DESIGN ADVICE, WEB TOOLS, SAFETY INFORMATION, AND OTHER RESOURCES "AS IS" AND WITH ALL FAULTS, AND DISCLAIMS ALL WARRANTIES, EXPRESS AND IMPLIED, INCLUDING WITHOUT LIMITATION ANY IMPLIED WARRANTIES OF MERCHANTABILITY, FITNESS FOR A PARTICULAR PURPOSE OR NON-INFRINGEMENT OF THIRD PARTY INTELLECTUAL PROPERTY RIGHTS.

These resources are intended for skilled developers designing with TI products. You are solely responsible for (1) selecting the appropriate TI products for your application, (2) designing, validating and testing your application, and (3) ensuring your application meets applicable standards, and any other safety, security, or other requirements. These resources are subject to change without notice. TI grants you permission to use these resources only for development of an application that uses the TI products described in the resource. Other reproduction and display of these resources is prohibited. No license is granted to any other TI intellectual property right or to any third party intellectual property right. TI disclaims responsibility for, and you will fully indemnify TI and its representatives against, any claims, damages, costs, losses, and liabilities arising out of your use of these resources.

TI's products are provided subject to TI's Terms of Sale (www.ti.com/legal/termsofsale.html) or other applicable terms available either on ti.com or provided in conjunction with such TI products. TI's provision of these resources does not expand or otherwise alter TI's applicable warranties or warranty disclaimers for TI products.

Mailing Address: Texas Instruments, Post Office Box 655303, Dallas, Texas 75265
Copyright © 2020, Texas Instruments Incorporated